

“Windy”[®] SP Port-O-Brake

OPERATIONS MANUAL

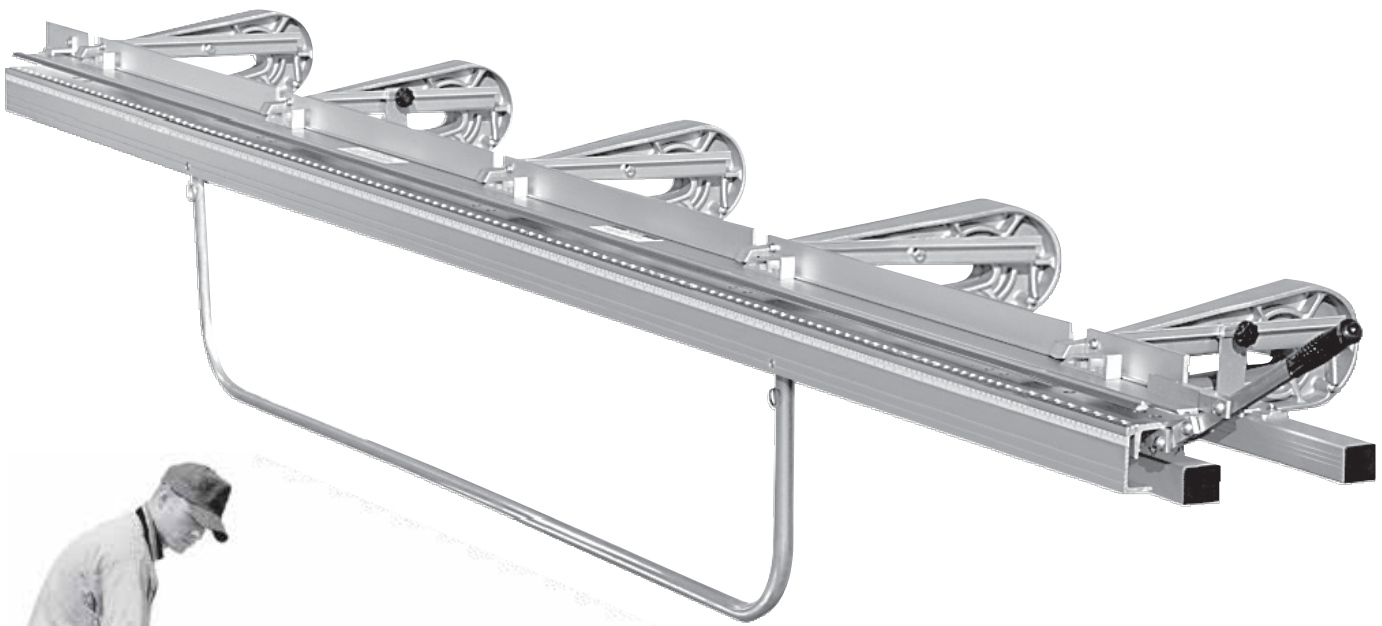

“Windy” SP Port-O-Brake • shown with optional PRO-Coiler • and Light Duty Folding Legs.

CONTENTS

Introduction	2
Setup Instructions	3
Accessories	4
Hints for Bending	5
Examples of Common Trim Shapes	6
Troubleshooting	7
Cleaning Locking and Clamping Surface	8
Replacing Stainless Edge	9
Replacing Vinyl Strip	9
Replacing Wedges	10
Replacing Hinges	10
Replacing Shoe Castings	11
Windy Parts List	12

All Tapco Tools are made under one or more of the following U.S. Patents:

3,161,223	4,321,817	4,651,553	4,489,583
4,493,200	4,445,356	4,372,142	4,766,757
3,817,075	4,557,132	4,240,279	4,671,094
3,482,427	4,494,397	3,559,444	5,343,728
5,353,620	5,505,069		

Other U.S. & Foreign Pats. Pend.

Introduction

Congratulations on your purchase of a quality built Tapco "Windy" SP Port-O-Brake®. With proper care and maintenance, your Port-O-Brake® will provide you with many years of excellent service.

This booklet will outline in detail the simple steps to properly maintain your Port-O-Brake® and the proper procedure to use should your Port-O-Brake® need repair. By following our General Hints you can prevent many costly repairs.

If you find that your Port-O-Brake® needs a replacement part, it can be obtained by contacting your local Tapco Tools distributor.

GENERAL HINTS

1. Clean your Port-O-Brake® at least once every 40 hours of use. Follow the fast and easy procedure outlined on page 9.
2. Use a high quality cleaning solvent such as Gum-Out® or WD-40®.
3. Use only lightweight lubricants such as "3 in 1" Oil®, or 30 wt. oil. Note: Do not use vasoline, axle grease, or graphite because they tend to "hold" dirt.
4. Use only clean shop rags that are free of dirt or metal chips.
5. Do not use your Brake around your saw table as the cuttings may get between clamping members and cause excessive wear or material scratching.

"WINDY" SP MATERIAL BENDING CAPACITIES

Soft Aluminum.....	Up to .030
Hard Aluminum (Gutter Coil).....	Up to .022
Steel*	Up to 29 ga
Galvanized Steel*	Up to 29 ga
Copper Annealed	Up to 12 oz
Copper Soft	Up to 24 oz
Vinyl.....	All standard vinyl sidings

*Specifications may vary with temper of material

For Your Records

Complete the information below and save with this manual for future reference.

Model and Serial Number

Date and Place Purchased

Setup Instructions

Attaching the Locking Handle

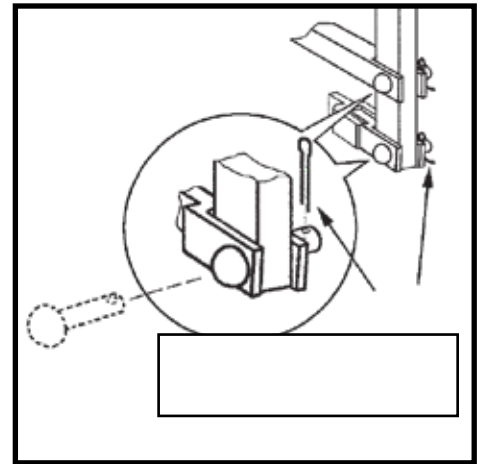
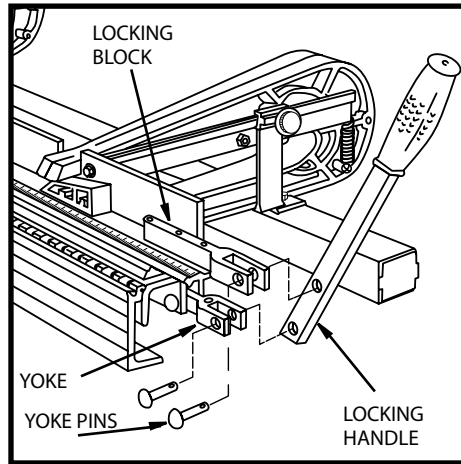
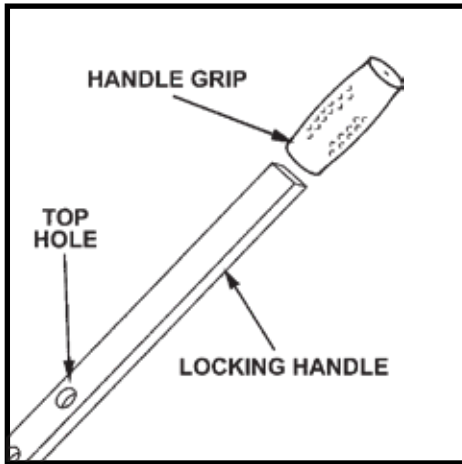

- 1** Remove Locking Handle and Handle Grip from parts bag. Press Grip over end of Locking Handle and slide down until Grip is firmly seated. Remove rest of parts from bag and proceed to next step.
- 2** Insert bottom end of Locking Handle into the bottom Yoke on right side of Port-O-Brake.[®] Align holes and insert Yoke Pin. Align top hole in Handle with holes in Locking Block of Slide Bar and insert second Yoke Pin.
- 3** Insert Cotter Pins through holes in ends of both Yoke Pins. Bend one leg of each cotter pin forward to secure Yoke Pin.

Setting Up the Lifting Handle

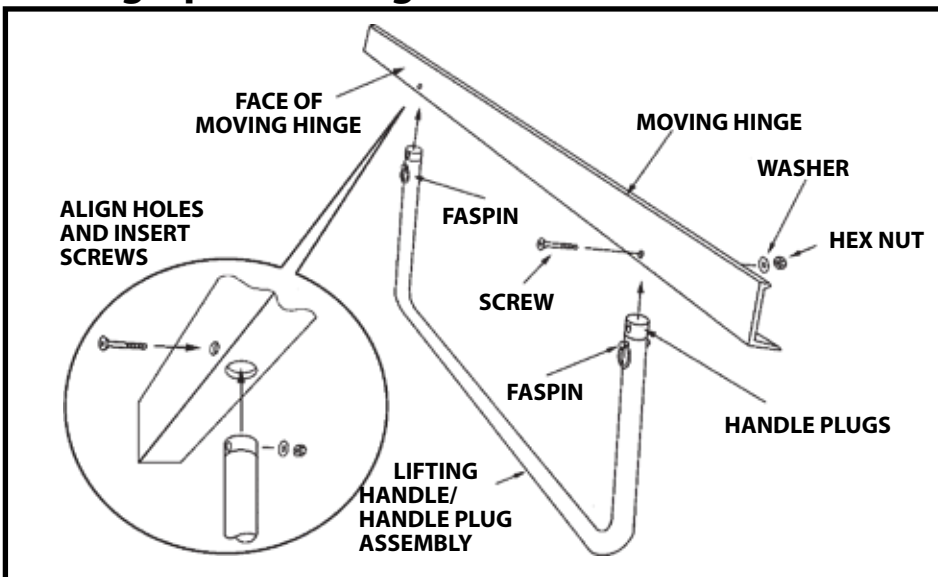

- 1** Insert the ends of the Lifting Handle/Handle Plug Assembly up through the holes in the bottom of the Moving Hinge. Align holes in the Handle Plugs with the holes located in the face of the Moving Hinge.
- 2** With holes aligned, insert screws through Moving Hinge and into Handle Plugs. Place washers over ends of screws in back and tighten with hex nuts. Handle can now be detached from Handle Plugs by removing Faspins.

Accessories for the "Windy" SP Port-O-Brake®

Pro-Coiler™

The portable coil holder that becomes an integral part of your "Windy" SP Port-O-Brake®

- Keeps the coil off the ground and always in front of you
- Helps ensure you get straight cuts all the time
- Helps increase production and eliminate waste
- Holds 24" wide by 100' coil



"Windy" SP Port-O-Brake® with optional accessories: Pro-Coiler and Light Duty Folding Legs

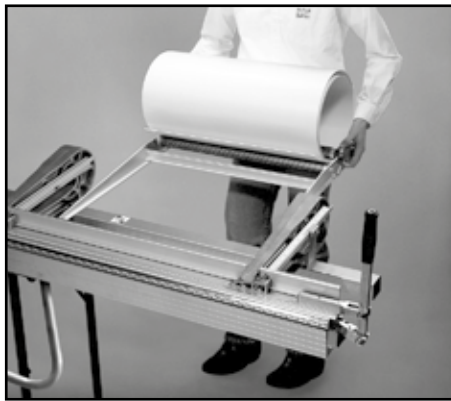

Hooks on and detaches in seconds. Allows you to roll out and cut coil squarely to your exact length.

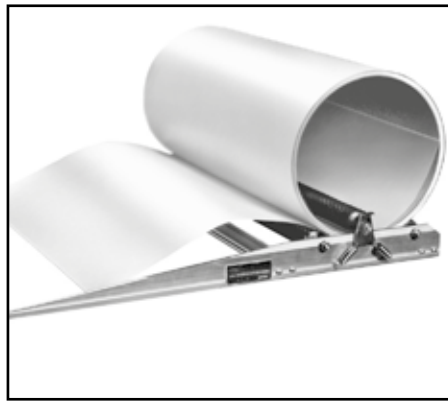

Change coils quickly by simply unhooking Roller Clip at one end and inserting new coil.

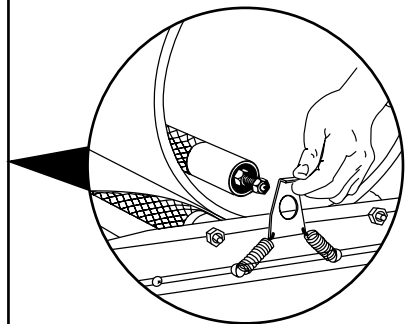

Installing the Light Duty Folding Legs

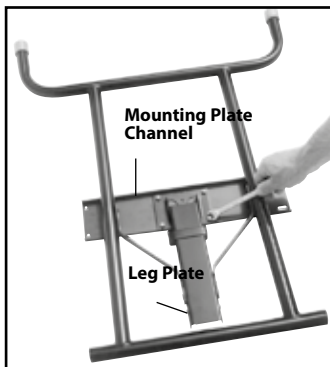

1 Position leg plates into mounting plate channels, align holes and install nuts and bolts provided.

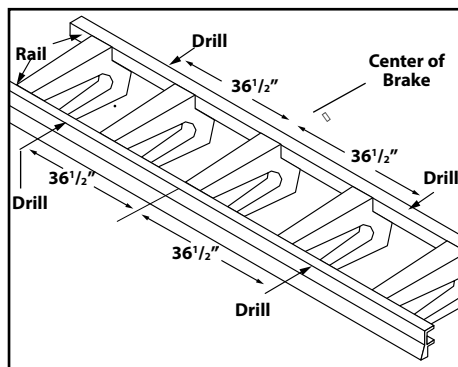

2 Invert Brake. From center of Brake, measure outward along each rail 36 1/2" and drill one pilot hole in center of each rail using an 11/64" drill bit.

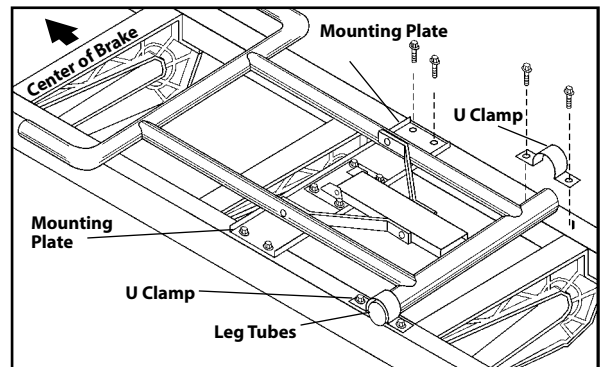

3 Set legs onto Brake with leg tubes near drilled pilot holes. Place "U" clamps over leg tubes, align holes and install sheet metal screws. Drill remaining holes through clamps and install screws. Install screws also in mounting plates as shown.

Traditional Bending Techniques

Helpful Hints for Trim Work

1. Measure the total length of the particular trim area to be covered and divide by the length of your Brake to determine the number and length of trim pieces needed.
2. Determine the dimensions of each section of the desired trim shape by measuring that particular profile to be covered. As an aid, make a pattern by bending a 1" strip of coil to get your exact profile.
3. Transfer the dimensions in Hint #2 to each end of a piece of trim coil by making a 1/4" slit in the metal with a pair of shears. These marks now become the bending points and are visible from either side. On longer lengths fold the coil over as shown and snip both ends at once. This saves time and ensures accuracy.



4. Lock the pre-marked coil blank into the Brake with the cut marks located directly under the outer edge of the Stainless Bending Edge. Lock Brake. To cut off the coil with a razor knife, score the metal against the Stainless Bending Edge. Now bend the metal up and push back down by hand until the exposed section breaks off. It may require 2 or 3 repetitions. When breaking material repeatedly, bending to just 45° will avoid rounding the edge.

5. For some shapes you will be removing the piece and either spinning it front to back or flipping it face up or face down to make the next bend. Use proper care to avoid damaging the piece especially on windy days.
6. Don't fit your trim parts too tight. This will complicate the joints where parts overlap. A one inch (1") lap joint is enough to allow for expansion and contraction. Trim should be lapped so that laps are facing away from traffic areas.
7. When face nailing try to nail the trim parts on an area that will make the nails less conspicuous. Fasten at laps. Also when face nailing, use just enough nails to secure trim; **DO NOT DRIVE NAILS TOO TIGHT** or you will dimple the trim.
8. **Remember**, when designing shapes you are hanging a cover over the wood parts, not laminating a skin-tight surface. This is called "Floating Your Trim". Allow for irregularities in the wood because your formed trim shapes are straighter than the wood trim moldings or boards you are covering.
9. With practice, you'll learn to overbend or underbend certain sections to achieve a pressure fit of your trim parts which will, in turn, require fewer nails and give your job a more finished appearance.
10. Follow the suggested sequence of bends for the example given or you may be "trapped" and unable to complete a shape. Tailor the same steps to your own custom shapes.

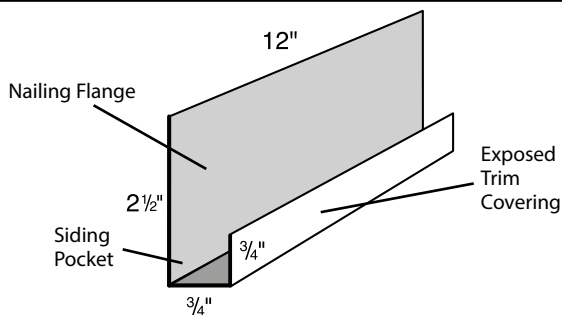

1. This shape is basic to all other shapes made with the "Windy" SP Port-O-Brake®. Take time to practice before you proceed with other shapes.
2. To begin, cut off a piece of coil 4 inches wide by about one foot long (as shown at right).
3. Place your tape measure on the coil and mark the coil with a pencil at 3/4" and again at the 1 1/2" mark beyond that. Make sure opposite sides are marked.
4. Now snip these marks as shown to the right so that they will be visible on both sides of the coil (for some shapes you will be turning your material both face up and face down).
5. Place sheet of coil into Brake with finished side down leaving only first set of 3/4" marks hanging out. (Generally, insert the largest part of the material into the Brake first.) Bend ① is at this mark so lock your brake on these marks and bend 90°.
6. Unlock the Brake and slide the material to the second set of marks ②. Bend 90° again to complete the shape.

Bending a Sample J-Channel

GENERAL INSTRUCTIONS FOR ALL EXAMPLES

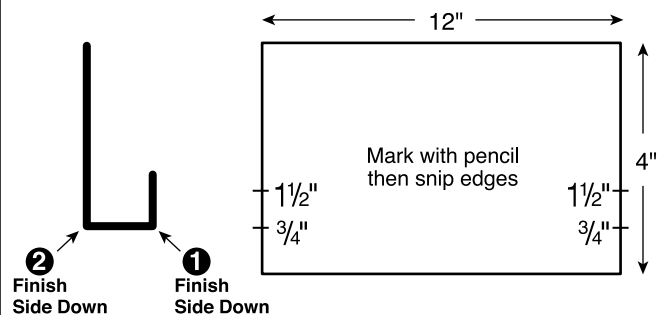

1. Numbers show the sequence of bends; thus ① would be the first bend and ② the second.
2. "Finish Side Up" indicates that the finished or exposed side of the trim is to be put into the Brake Facing Up.
3. "Finish Side Down" indicates that the finished or exposed side of the trim is to be put into the brake facing down.

Examples of Common Trim Shapes

Illustrated below are typical shapes used on common siding jobs which you can form with the "Windy" SP Port-O-Brake. The numbers indicate the recommended sequence of bends. "Finish Side Up" indicates that the exposed or finish side of the trim material is to be placed in the Brake facing up.

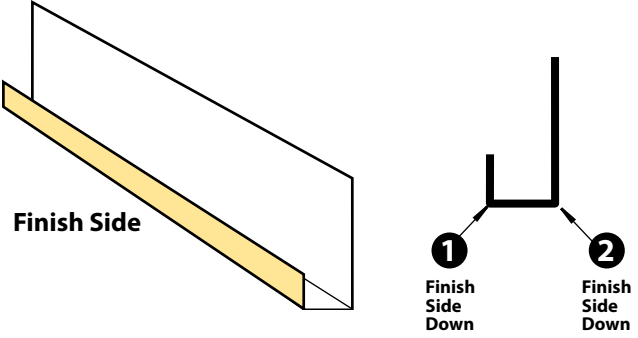
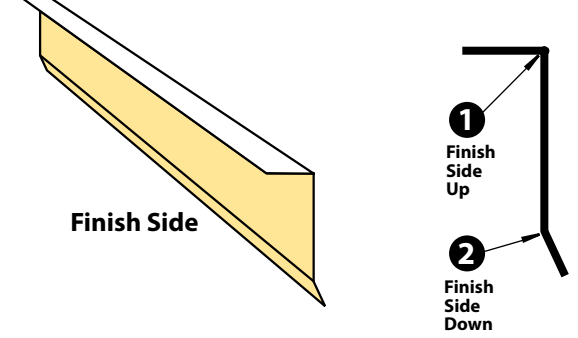
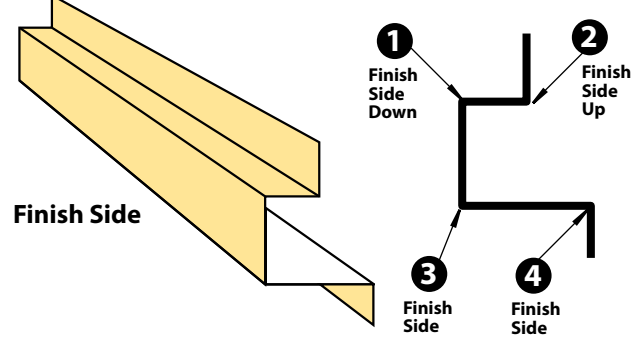
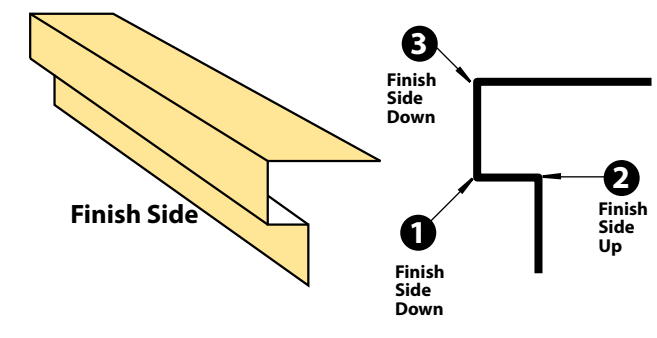
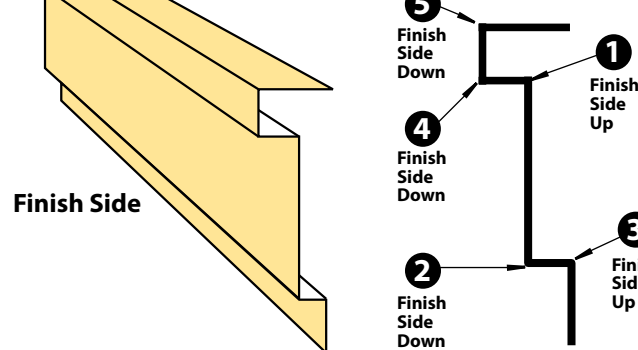
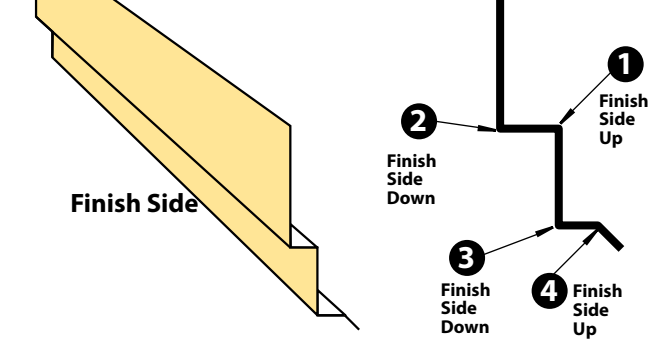
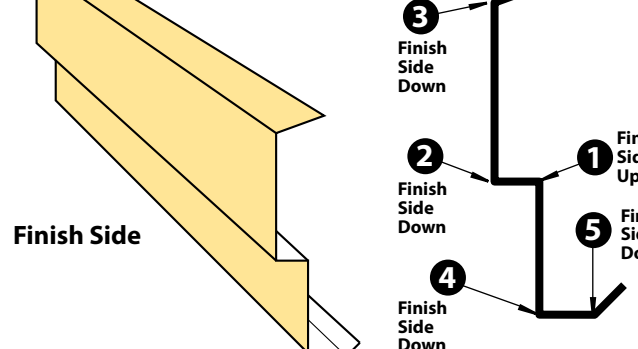
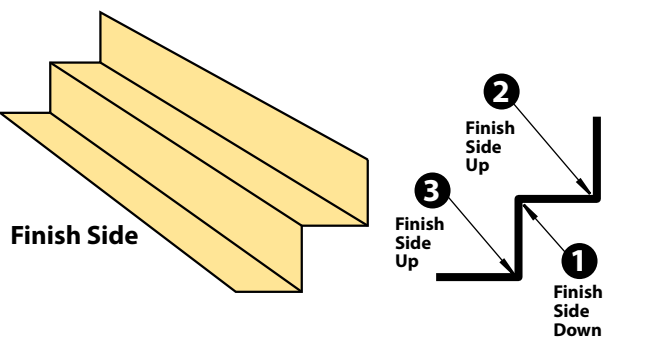
<p>J-CHANNEL</p> 	<p>DRIP CAP/SILL/MULLION</p> 
<p>BOX/DOOR CASING</p> 	<p>LINTEL</p> 
<p>FASCIA</p> 	<p>BRICK FRIEZE</p> 
<p>FRIEZE</p> 	<p>INSIDE CORNER</p> 

Trouble Shooting

MATERIAL SLIPPAGE

Material Slippage is caused by the Brake not locking properly or fully along the entire length.

To determine the need for Wedge Adjustment:

- A. Cut paper into sheets approximately 2" x 6".
- B. Insert paper into clamping position under each Shoe Casting.
- C. Lock Brake
- D. Try to remove paper while Brake is locked by lightly pulling on the paper. If paper slips out easily, that particular Casting should be adjusted.

Solution:

- A. Clean and lubricate Wedges, Sliding Bar, and Clamping Bar. (see page 9)
- B. Tighten Fasteners for Hinges, Yoke, and Wedges.
- C. Inspect Shoe Casting for damage due to dropping or other accidental abuse. Replace if necessary (see page 12).

SCRATCHES OR MARRING OF MATERIAL

- A. Do not use your Brake around your Saw Table as the cuttings may get between clamping members and cause excessive wear or material scratching.
- B. Wipe jaws clean during use to remove metal chips, dirt or shavings. This will prevent scratching of your clamping mechanism.
- C. If your material is getting scratched examine the Clamping Bar and Hinge for roughness or burrs. Replace worn parts.
- D. If you transport your Brake in the locked position, lock a piece of vinyl siding or cardboard between the clamping members. Vibration during transport can cause scoring of the clamping mechanism if dirt or foreign matter is present.
- E. Replace vinyl strip if excessively worn or nicked.

UNEVEN BENDING

Uneven bending or "overbending" is material being bent more in one section than in another.

Solution:

- A. Make sure material is being locked down securely prior to bending.
- B. Using Brake on uneven ground may cause some bowing or twisting to occur.
- C. Check fasteners on Fixed Hinge and Wedges for looseness and tighten. (see Replacing Wedges page 11)
- D. Check for cracked or broken Castings. Look on the top and underside of each casting. Replace part. (see page 12)
- E. Uneven bending may be caused by operator pulling on one end of the Lifting Handle rather than the center.
- F. Transporting your Brake other than in the flat working position may cause it to bow.
- G. Look for bow along the Fixed Hinge and Clamping Bar. These parts may need to be replaced.

Cleaning the locking and clamping surface

Tools needed: clean shop rag, commercial cleaning solvent such as Gum Out® or WD-40®, light weight oil



1 Open Brake

Move Locking Handle to Right. Follow steps 1, 2, and 3 in reverse order to reassemble.



2 Remove Top Yoke Pin

With Brake unlocked remove Cotter Pin from Top Yoke Pin and disengage handle.



3 Remove Sliding Bar

Grasp and pull Sliding Bar to the right and forward to remove. Turn upside down and rest on brake castings.



4 Loosen Dirt and Residue

Use Gum-Out®, WD-40® or quality commercial cleaning solvent on a clean shop rag and clean the bottom surface of the Sliding Bar.

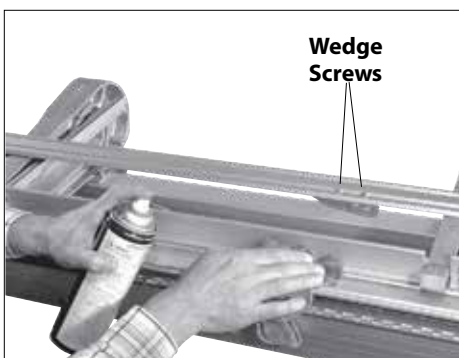

5 Clean Clamping Bar

Clean the bottom surface of the Clamping Bar in the same manner. Before reinstalling check that screws securing wedges are tight.

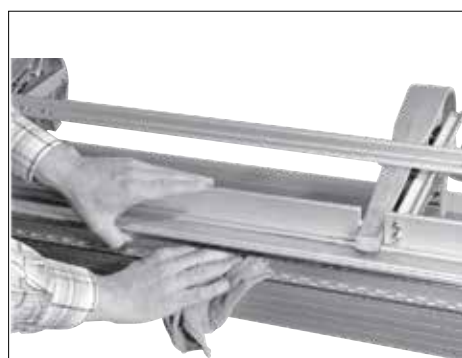

6 Clean Underneath Clamping Surfaces

Using solvent on a shop rag, clean upper and lower clamping surface as indicated and wipe dry. Do not apply oil here

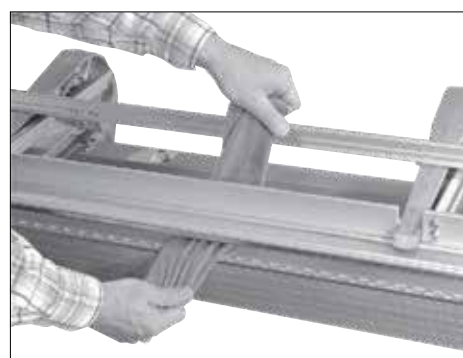

7 "Spot" Cleaning

For everyday cleaning, a rag may be used between the clamping surfaces with the Brake assembled



8 Oil Clamping Bar

Using any lightweight oil such as "3 in 1" or 30 Wt. motor oil, lightly lubricate the Clamping Bar.

Note: Do not use graphite, silicone or heavy grease as these "hold" dirt.

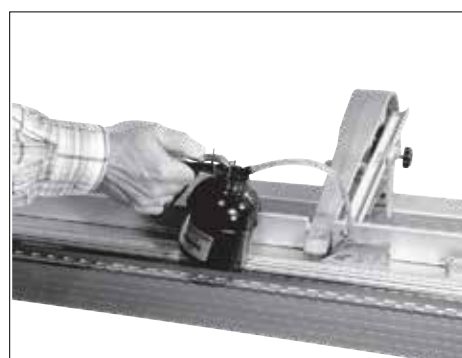

9 Replace Sliding Bar & Oil Wedges

Replace Sliding Bar making sure that it slides easily along the Clamping Bar. Wipe up excess oil. Clean and oil the Wedges now and regularly thereafter.

Replacing the Vinyl Strip

Tools needed: drill, #26 drill bit, hammer, slotted screw driver, light oil, pliers or vice grips, center punch, and safety glasses

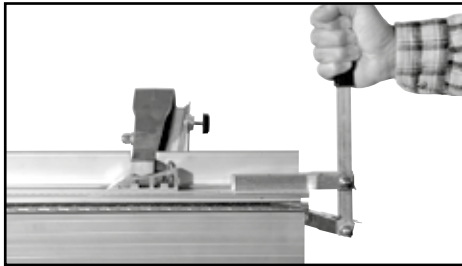

1 Close Brake
Move Locking Handle to left.

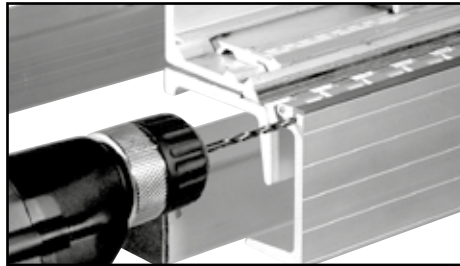

2 Drill Out "Center Punch" Marks
Clean out slots that hold Vinyl Strip at both ends of Brake using #26 drill bit.

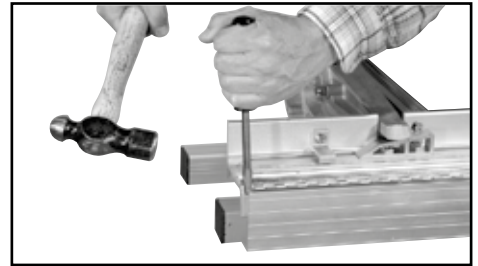

3 Loosen Vinyl Strip
Push Vinyl Strip from one end by tapping on the edge of upright screwdriver as indicated. Make sure opposite end of slot is free of dirt and obstruction. **CAUTION:** Avoid hitting hinge with hammer.

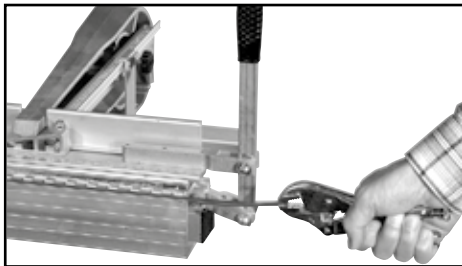

4 Remove Vinyl Strip
Grasp other end of strip with pliers and pull Strip out of slot. Check slot for burrs, metal chips, dirt, etc. and clean if necessary.

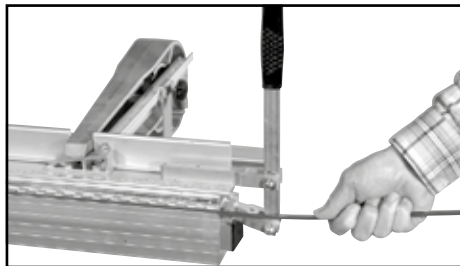

5 Replace Vinyl Strip
Replace Vinyl Strip by lightly lubricating leading end with small amount of oil while sliding into slot. Wipe off excess oil afterwards.

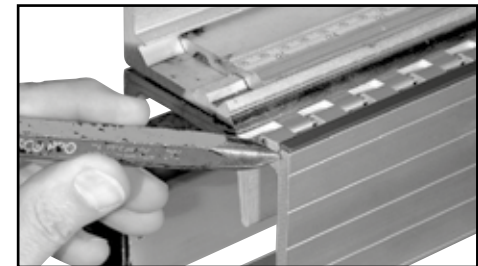

6 Punch Vinyl
When Vinyl Strip is in place "center punch" both ends to prevent slippage.

REPLACING THE STAINLESS BENDING EDGE

Tools needed: slotted screwdriver, rubber mallet, vice grip or pliers, center punch, hammer, and safety glasses

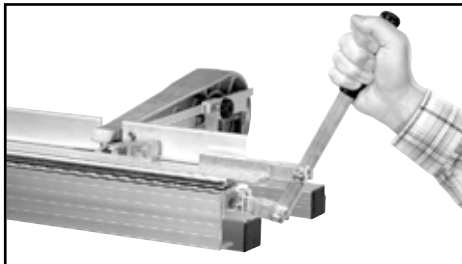

1 Open Brake
Move Locking Handle to the right.

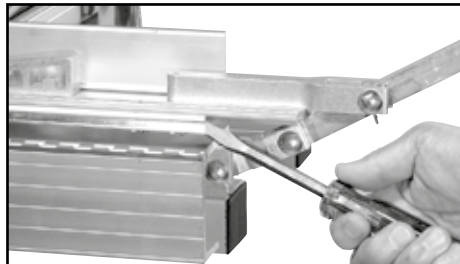

2 Loosen Stainless Edge
To loosen old Stainless Bending Edge, insert screwdriver behind one end as indicated and twist to release from end.

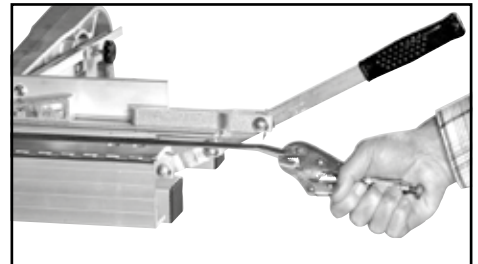

3 Remove Stainless Edge
Grasp one end of Stainless Bending Edge with pliers or vice grips and pull away with a twisting motion. **Note:** Stainless Bending Edge is not reusable after removal.



4 Install New Stainless Edge
Starting on end away from Locking Handle align new Stainless Edge flush with end of Clamping Bar and tap into place sideways with Rubber Mallet.



5 After replacement, "Center Punch" Stainless Bending Edge on ends to prevent possible sliding.

Replacing the Moving Hinge

Tools needed: electric drill, small drill bit, hammer, small diameter hard wire or narrow punch, vise grips or pliers, light oil, and safety glasses



- 1 Remove Handle**
Detach Faspin and remove Lifting Handle. Brake can be locked during this operation.

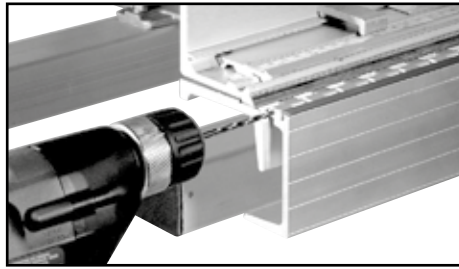

- 2 Clean Out Hinge Pin**
Before removing Hinge Pin, drill out "center punch" marks from ends of Hinge.

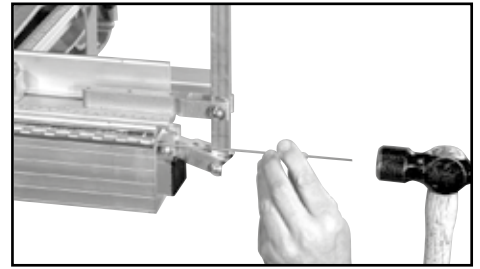

- 3 Loosen Hinge Pin**
Using small diameter hard wire or narrow punch and hammer, tap out Hinge Pin from one end.

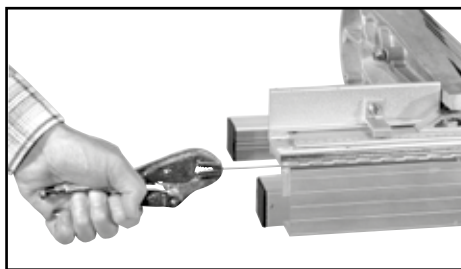

- 4 Remove Hinge Pin**
Grasp Hinge Pin at opposite end with pliers or vise grips and pull Pin out. Moving Hinge will now disengage and can be replaced.

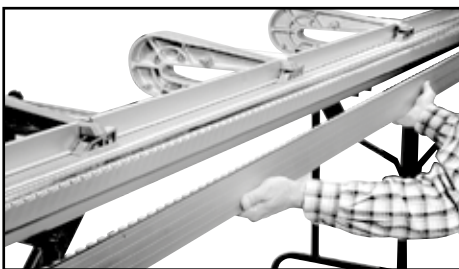

- 5 Remove Hinge**
NOTE: Have an assistant support the Hinge prior to removing the Hinge Pin.

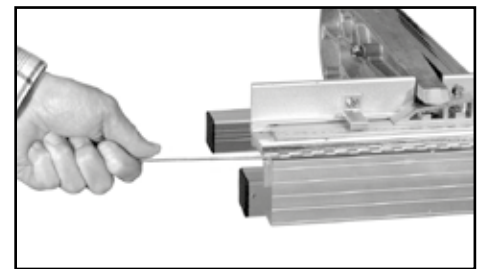

- 6 Replace Hinge Pin**
To install new Hinge and Hinge Pin, have assistant hold Moving Hinge while the Pin is inserted. When reinstalling the Hinge Pin lubricate the leading end with a light oil. Be careful not to bend it.

REPLACING WEDGES

Tools needed: clean shop rag, Phillips screwdriver, commercial cleaning solvent such as Gum Out® or WD-40®, light weight oil

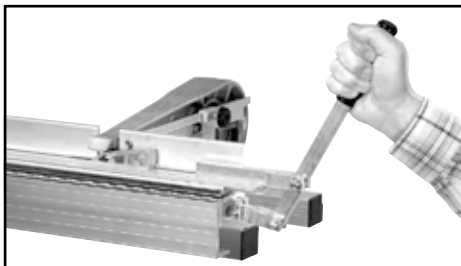

- 1 Open Brake**
Move Locking Handle to right.

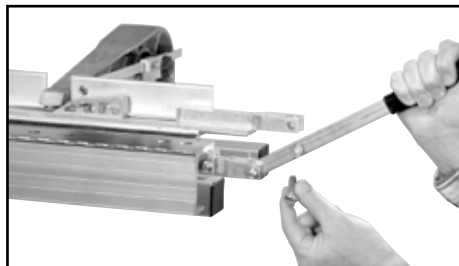

- 2 Remove Top Yoke Pin**
With Brake unlocked remove Cotter Pin from Top Yoke Pin and disengage handle.

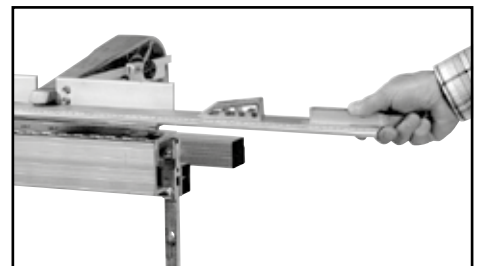

- 3 Remove Sliding Bar**
Grasp and pull Sliding Bar to the right and forward to remove.

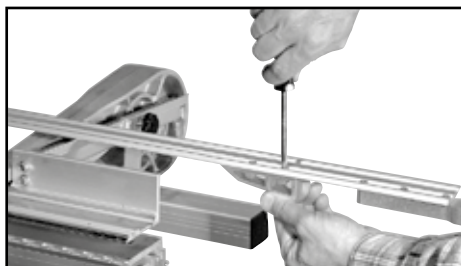

- 4 Remove Wedge**
With the Sliding Bar removed and inverted as indicated, remove the Flat Head Screws holding the Wedge to the Sliding Bar.

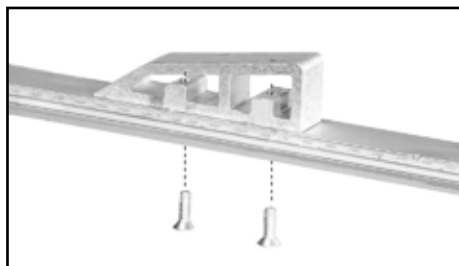

- 5 Replace Wedges**
Periodically check to insure that screws holding Wedges are tight. Loose screws will cause uneven locking.



- 6 Clean Sliding and Clamping Bar Before Replacing.**
Clean surfaces. (see page 9)

Replacing the shoe Casting

Tools needed: socket wrench with 7/16" socket, Phillips screwdriver

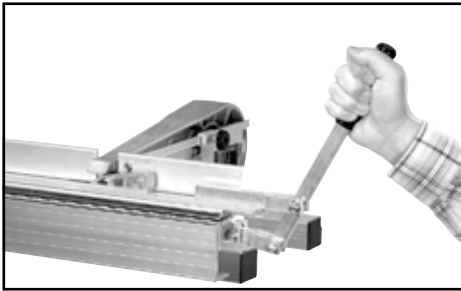

- 1 Open Brake**
Move Locking Handle to right.

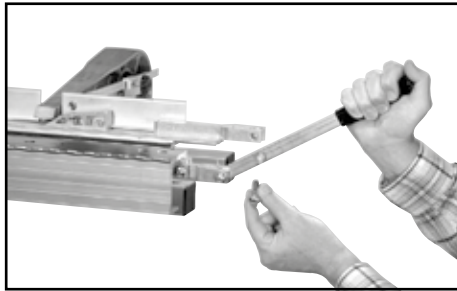

- 2 Remove Top Yoke Pin**
With Brake unlocked remove Cotter Pin from Top Yoke Pin and disengage handle.

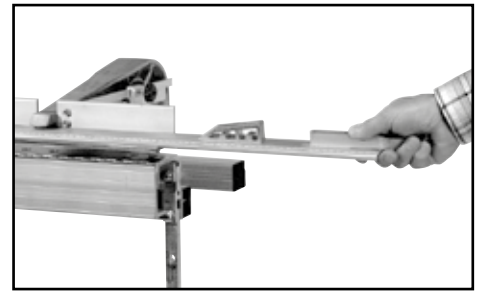

- 3 Remove Sliding Bar**
Grasp and pull Sliding Bar to the right and remove.

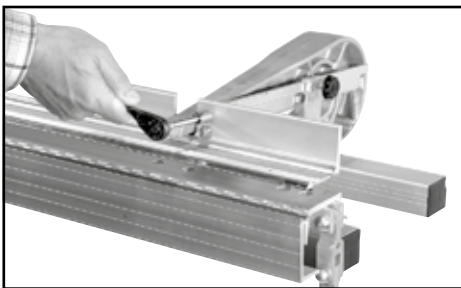

- 4 Remove Hex Head Screws Holding Clamping Bar**
This will allow you to reach flat head screws holding Fixed Hinge.

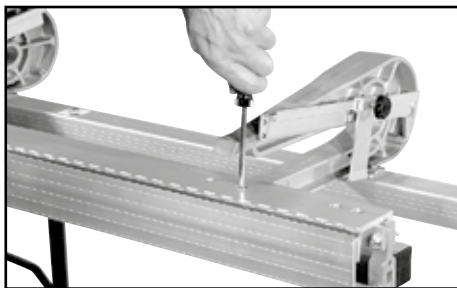

- 5 Remove Hex Screws from Front of Shoe Casting**
Remove Flat Head Screws from Fixed Hinge on the Shoe Casting to be replaced.



- 6 Remove Hex Screws from Back of Shoe Casting**
Remove the four (4) Hex Head Screws holding the Shoe Casting to the Bottom rails front and back.



- 7 Remove Pivot Arm**
Remove Pivot Arms and springs and replace the Shoe Casting. When replacing, make sure all fasteners are tight and flush.

Parts List

"Windy"® SP Port-O-Brake

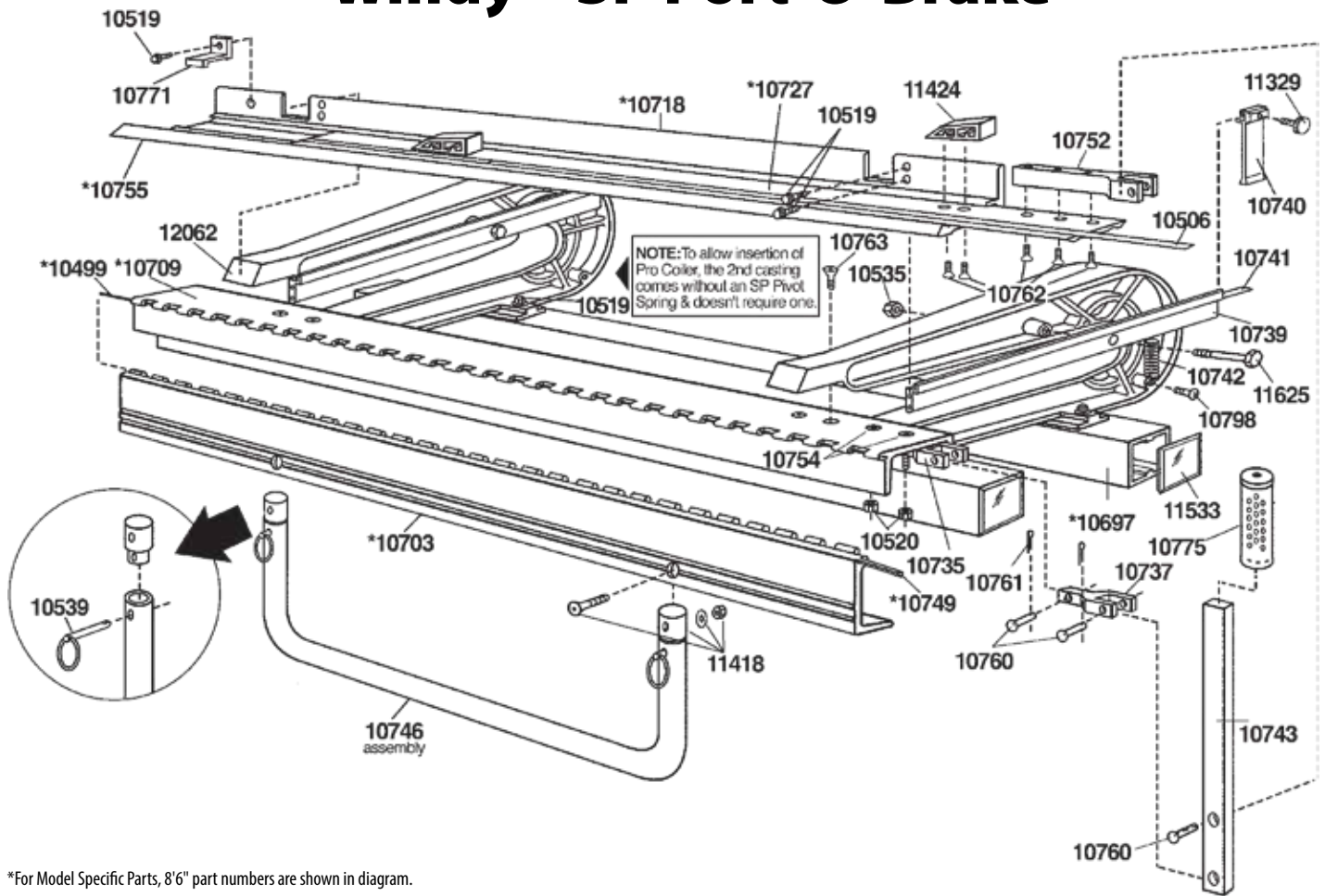

*For Model Specific Parts, 8'6" part numbers are shown in diagram.

Item #	Description
10499	8'6" Hinge Pin
10500	10'6" Hinge Pin
10505	10'6" Tape Measure
10506	8'6" Tape Measure
10519	1/4-20 X 3/4" Hex Wash HD
10520	1/4-20 Nylock Hex Nut
10535	3/8-16 Nylock Hex Nut
10539	1/4" X 1 1/4" Faspin
11533	Back Rail Cap
10697	8'6" Bottom Rail
10699	10'6" Bottom Rail
10703	8'6" Moving Hinge
10705	10'6" Moving Hinge
10709	8'6" Fixed Hinge
10712	10'6" Fixed Hinge
10718	8'6" Clamping Bar
10721	10'6" Clamping Bar

Item #	Description
10727	8'6" Slide Bar
10729	10'6" Slide Bar
10735	Fixed Yoke
10737	Pivot Yoke
10739	Pivot Arm
10740	Pro/Sp Material Stop
10741	Pivot Arm Tape
10742	Pivot Spring
10743	Locking Handle
10746	Lifting Handle Assembly
11625	3/8-16 X 3 1/4" Hex Cap Bolt
10749	8'6" Vinyl Strip
10750	10'6" Vinyl Strip
10752	Locking Block
10754	1/4-20 X 1 3/4" Phil Fl Hd Sc
10755	8'6" Stainless Edge
10756	10'6" Stainless Edge

Item #	Description
10760	Yoke Pin
10761	3/32" Cotter Pin
10762	10-24 X 5/8" Phil Flat HD Sc
10763	1/4-20 X 3/4" Phil Fl Hd Sc
11329	1/4-20 X 1" Knurled Knob
10771	Slide Bar Retainer
10775	Locking Handle Grip
10798	10-24 X 5/8" Phil Pan Hd Sc
11418	Windy Handle Plug Kit
	SP Handle Plug (2)
	1/4" Lock Washer (2)
	1/4-20 X 1 3/4" Slot Fl Hd Sc (2)
	1/4"-20 Hex Nut (2)
11424	Wedge (6)
12045	Windy "SP" Parts Bag
12062	C Casting

Tapco-Europe-Tools.com | +44 (0)1482 880478

Westlake

© 2026 Westlake

TT88150 1/26