

Snap Stand[®]

OPERATIONS MANUAL



Shown with optional Wheel Kit

CONTENTS

- General Instructions
- Wheel Kit Installation
- Installing a Brake on Snap Stand
- Removing Brake Snap Stand
- Installing ProTrax or MaxTrax on Snap Stand
- Removing the ProTrax or MaxTrax

Setting up your Snap Stand®

STEP 1

To open each Leg Set, push in the snap button and move each leg outward to the working position. Figure 1A below shows the leg set as shipped while Figure 1B shows the leg set open (working position). Make sure that the snap button pops up to lock each leg.

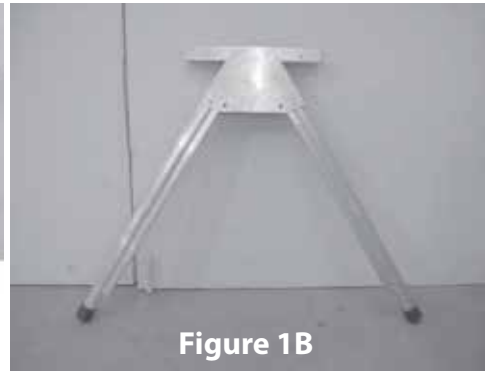

STEP 2

Attach the Cross Braces to the Leg Sets. With the snap button of the Leg Set pointing to the outside, snap the Cross Braces into position. See Figures 2A and 2B below.

Note: Be sure the C-shape of the Cross Brace is mating the leg as shown in Figure 2C below. See Figures 2A and 2B below.

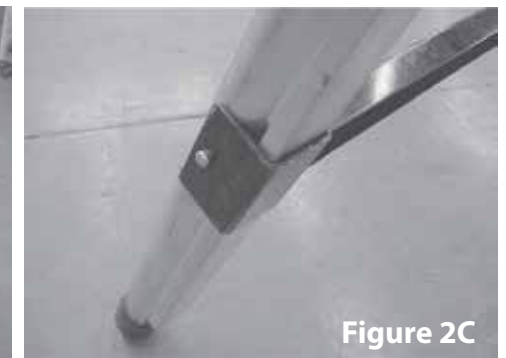
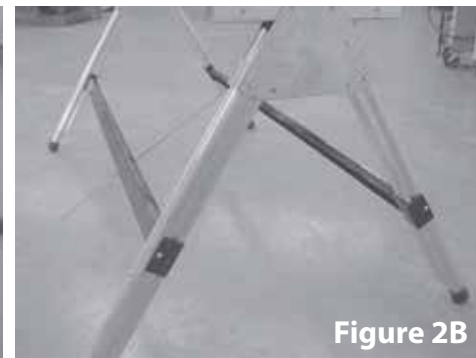
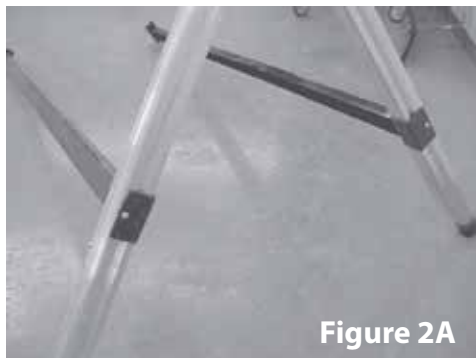

Attaching Optional Wheel Kit



STEP A

Insert the wheel assembly into the leg of the Snap Stand as shown in the figure above. Tap the bracket with a hammer to wedge it tightly into the leg. Repeat this process for the other leg.



Use one of these positions to stop the stand from rolling.

STEP B

To prohibit the stand from rolling on the wheels, lock the leg extensions into one of the bottom two locking positions. See figure above. If the leg extensions are in one of the other 3 positions, the wheels are in contact with the ground and are free to roll.

STEP C

To remove the wheel assembly, tap the bracket downward with a hammer to disengage.

Installing a Brake on Snap Stand®

STEP 1

Using the 1/4-20 bolts and lock washers provided, fasten the brake mounts to the Leg Set. Depending on which brake you're using, choose the correct holes as shown in the figure at right.

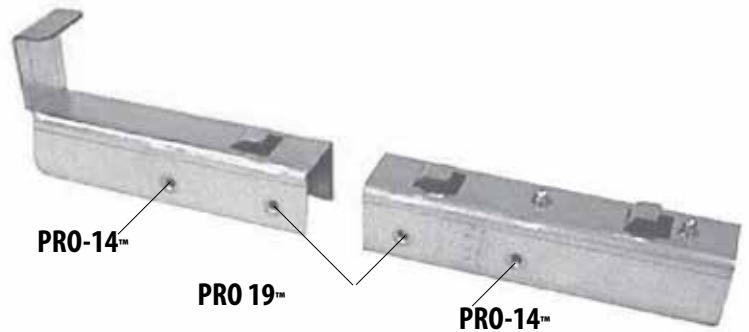

STEP 2

The snap buttons will be towards the working side of the brake. Repeat Step 1 for the other Leg Set. Be sure both ends of the Snap Stand are going the same direction (with the snap buttons on the same side). See Figure 2 above.

STEP 3

Place the brake on the assembled Snap Stand with the Back Rail of the brake clearing the adaptor hook as shown in Figures 3A and 3B above.



The snap button will be covered by the fixed hinge of the brake as in Figure 3C above.

STEP 4

Push the brake firmly rearward into the adaptor hooks. The snap buttons by the front clips will pop up and secure the brake on the Snap Stand. See Figure 4 above. The brake is now ready for use.

Removing the Brake:

1. Removing the brake from the Snap Stand is essentially the opposite of attaching it to the stand.
2. Lifting the Moving Hinge, depress the snap button and pull the brake forward far enough to hold each snap button down.
3. Be sure the box rail is out of the Rear Clip. The brake can now be removed from the stand.
4. Reverse Steps 1 and 2 on page 2 to disassemble the stand for transport.

Installing a ProTrax™ or MaxTrax™ on Snap Stand®

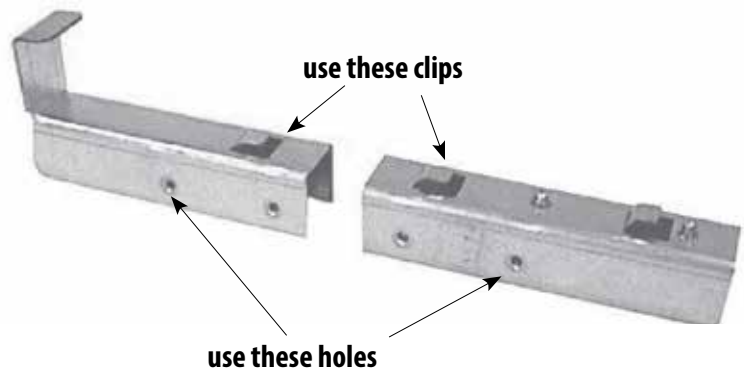
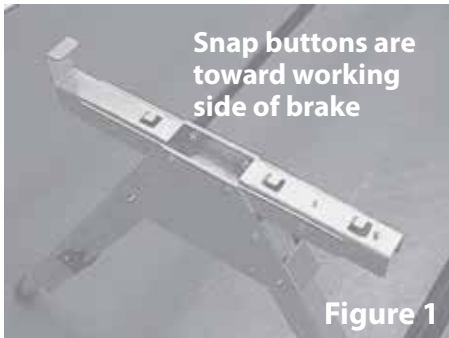

STEP 1

Using the 1/4-20 bolts and lock washers provided, fasten the ProTrax/MaxTrax mounts to the Leg Set. The snap buttons will be on the working side of the brake. Repeat for the other Leg Set. Be sure both ends of the Snap Stand are going the same direction (with the snap buttons on the same side) See Figure 1 above.

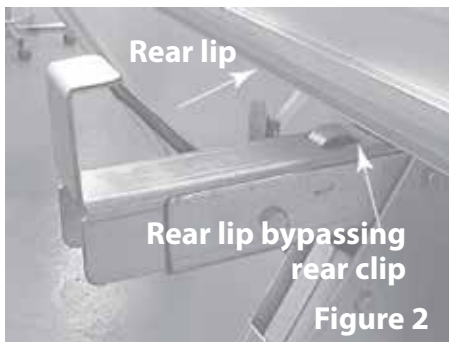

STEP 2

Place the ProTrax/MaxTrax on the Snap Stand Assembly with the rear lip of the sub structure clearing the rear clip. See Figure 2 above.



STEP 3

The snap button will be covered by the front sub structure of the ProTrax/MaxTrax. See Figure 3 above.

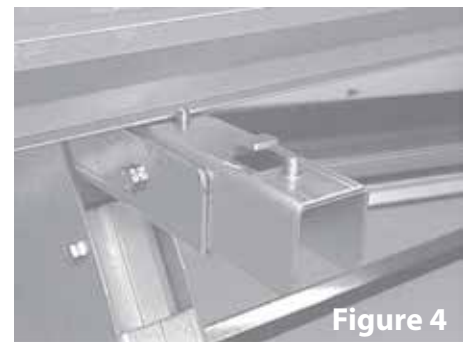

STEP 4

Push the ProTrax/MaxTrax firmly rearward into the rear clips. The snap buttons will pop up and secure the saw table on the Snap Stand. See Figure 4 above.

Removing the ProTrax or MaxTrax

1. Removing the ProTrax/MaxTrax from the Snap Stand is essentially the opposite of attaching it to the stand.
2. Depress the snap button and pull the saw table forward far enough to hold each snap button down.
3. Be sure the lip on the rear sub structure is out of the Rear Clip. The ProTrax/MaxTrax can now be removed from the stand.
4. Reverse Steps 1 and 2 on page 2 to disassemble the stand for transport.

Tapco-Europe-Tools.com | +44 (0)1482 880478

Westlake

© 2026 Westlake

TT88150 1/26