

Produces factory quality cuts in coil stock and vinyl siding right on your Port-O-Bender saving you time, reducing waste and conserving the life of your Port-O-Bender.

PRO Cut-Off and MAX Cut-Off

- Quickly, safely and easily makes factory quality cut offs in coil, PVC coated coil and all vinyl.
- Cuts up to .030 aluminum and all vinyl straight and accurate with a burr-free edge every time.
- Lightweight aluminum construction built to last.
- Hardened and captured tool steel cutting knives.
- Eliminates use of dangerous utility knives and shears.
- Saves time and labor in scoring and breaking off material.
- Pays for itself by reducing scrap and eliminating knifing damage to costly bending hinges.
- An indispensable tool for every professional!

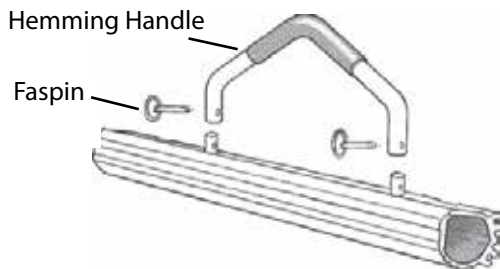
Adapts to any Pro-III, Pro 2000, or MAX-I-MUM Port-O-Bender



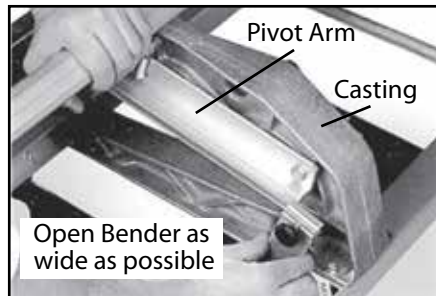
SETTING UP CUT-OFF

List of Parts: (1) Pro/MAX Cut-Off, (2) Material Stop Kit #11404, (1) Hinge Clip Kit #11413, (1) 10-24 x 5/8" Phillips screw.

Tools Needed for Initial Set Up: hammer, punch or nail set, 9/16" wrench, Phillips screw driver.



1. Disconnect the Hemming Handle from your Bender by releasing the Faspins. This will allow the Bender to fully open making it easier to slide Cut-Off Stops onto the Pivot Arms.



2. Slide material stop onto Pivot Arms from rear as shown. **Note:** Recommended locations are on the second castings in from each end of your bender.



IMPORTANT: 5" mark on tape measure should be inserted first.

3. Slide measuring tapes into Pivot Arm slots from rear of Pivot Arm till they stop. Tape measures take into account 1-1/2" difference between the bending edge and the shear point of Cut-Off for accurate cuts.



4. Secure the tape measures in place by "punching" down the edge of the pivot arm onto the tape measure. Use a standard nail set or punch.

IMPORTANT! Read this safety information before using product.

1. Always keep hands and fingers clear of the knives during all phases of use.
2. If using both hands to push tool through material, ensure hands are not in the path of the exiting material as it leaves the rear area of the tool.
3. Remove cut-off from anvil prior to bending material. Failure to do so can cause the tool to fall from brake resulting in tool damage or personal injury to user.
4. Never use tool to cut material not firmly clamped in brake.

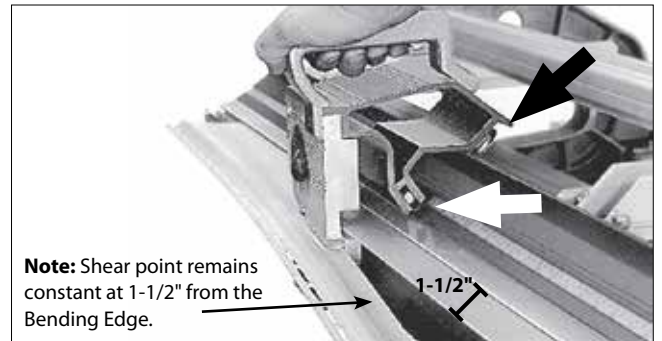
See other side for operating instructions.

Using Your CUT-OFF

- **IMPORTANT:** For straight, ripple free edges the moving hinge **MUST** be secured in place at a 90° angle by the Hinge Clip on your Bender (See Figure 1 below). Hinge Clip is included if there is not one already on your Bender.
- The shear point of the **CUT-OFF** remains a constant 1 1/2" from the bending edge (See note in Figure 2 below).
- The overall **length** of the material to be cut must be at least 6" less than the overall length of your Port-O-Bender.
- One end of the material to be cut should be no closer than 6" from the right side of your Port-O-Bender in order to allow the **CUT-OFF** to be placed on the track.
- The **CUT-OFF** is designed to cut from right to left as you face your Port-O-Bender. It is best to "push" the **CUT-OFF** "through" the material in a continuous motion across the Bender as shown in Figure 3.
- **CAUTION: Do not open Bender or attempt to bend** with **CUT-OFF** in track on top of Bender or it may fall.

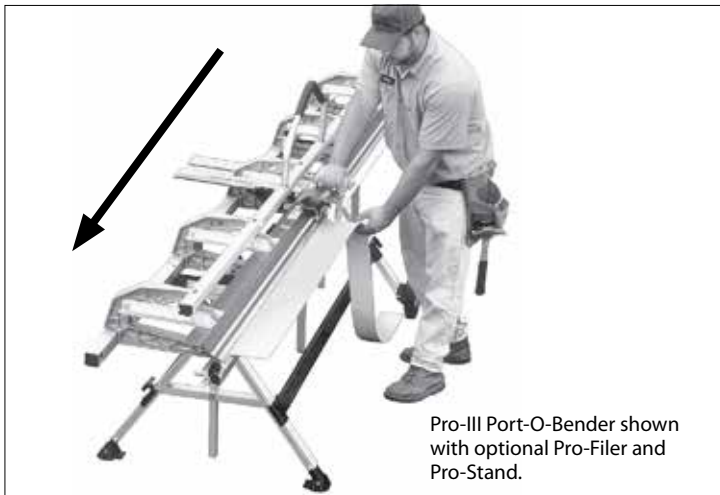


Figure 1. The Hinge Clip keeps the Moving Hinge in a 90° position for ease of aligning and cutting material. To install Hinge Clip, locate pre-drilled hole on **BOTTOM** right side of Moving Hinge. Align holes in Clip and Hinge as shown and insert Phillips head screw provided.



Note: Shear point remains constant at 1-1/2" from the Bending Edge.

Figure 2. Engage Guide Rollers correctly. Make sure both front and back rollers are seated in their tracks. **Note:** large arrows in illustration above.



Pro-III Port-O-Bender shown with optional Pro-Filer and Pro-Stand.

Figure 3. Use proper technique to push **CUT-OFF** through the material with a smooth, constant motion from right to left. Do not stop in the middle or cut with a back and forth motion. Use a piece or two of scrap material to practice.



Figure 4. When not in use, **CUT-OFF** can be stored on the Storage/Coupling Nut on the right end of the Bender. **Do not open or attempt to use Bender** with Cut-Off on top.

CAPACITIES

PRO CUT-OFF

All vinyl trim and coil
Aluminum: up to .030 low temper
Galvanized steel: up to 28 ga.
Copper: up to 16 oz.

MAX CUT-OFF

Aluminum: up to .050
Galvanized steel: up to 20 ga.
Soft Copper: up to 32 oz.
Stainless Steel: up to 24 ga.

Tapco-Europe-Tools.com | +44 (0)1482 880478

Westlake

© 2026 Westlake

TT88150 1/26