

INSTALLING LIGHT DUTY FOLDING LEGS

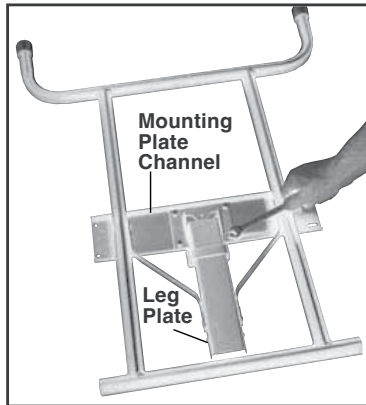

STEP 1: Position leg plates into mounting plate channels, align holes and install nuts and bolts provided.

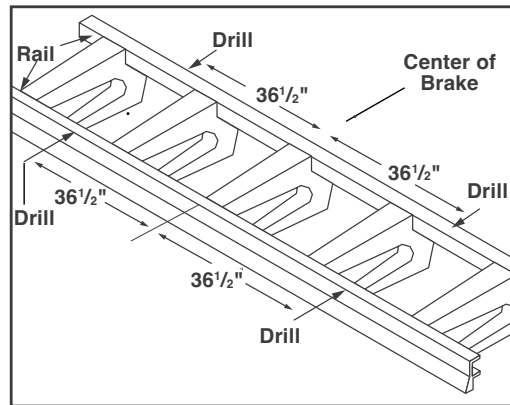

STEP 2: Invert brake. From center of brake, measure outward along each rail 36-1/2" and drill one pilot hole in center of each rail using an 11/64" drill bit.

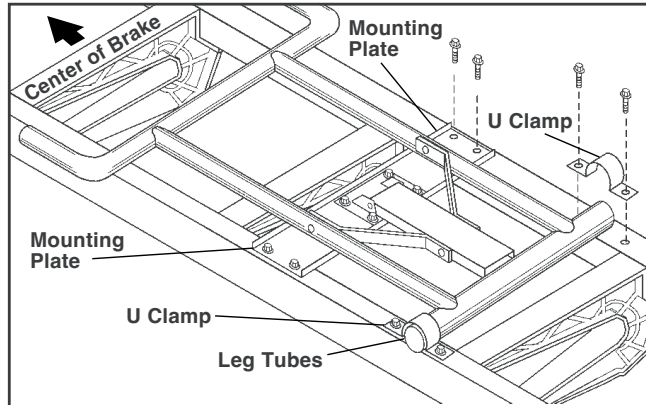

STEP 3: Set legs onto Brake with leg tubes near drilled pilot holes. Place "U" clamps over leg tubes, align holes and install sheet metal screws. Drill remaining holes through clamps and install screws. Install screws also in mounting plates as shown.

Tapco-Europe-Tools.com | +44 (0)1482 880478