

Brake Buddy[®]

OPERATIONS MANUAL

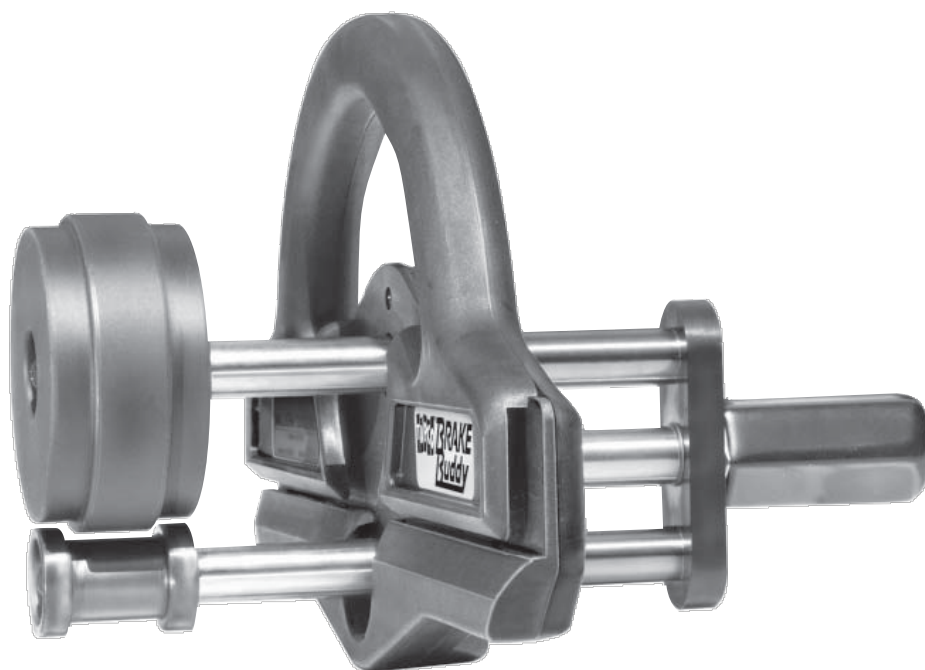

- Make multiple bends in fascia.
- Strengthens fascia against oil canning.
- Gives a decorative appearance to trim work.
- Makes brick mold quick and easy.
- Easily adds to the professional look of a job.
- Each lightweight unit is sold with 2 sets of rollers.
- Can be used on any brake.

TAPCO BRAKE BUDDY®

The Brake Buddy is acknowledged by experienced applicators to be the best new tool available in years. The Brake Buddy puts bends in fascia, window trims, frieze boards, porch posts, beams or nearly any piece of aluminum, PVC coated aluminum or vinyl coated stock.

The special alignment feature of the tool allows the applicator to run a stiffening, decorative rib on piece after piece, making the bends in exactly the same place. Trim pieces will line up on the house perfectly, end to end, or mitered.

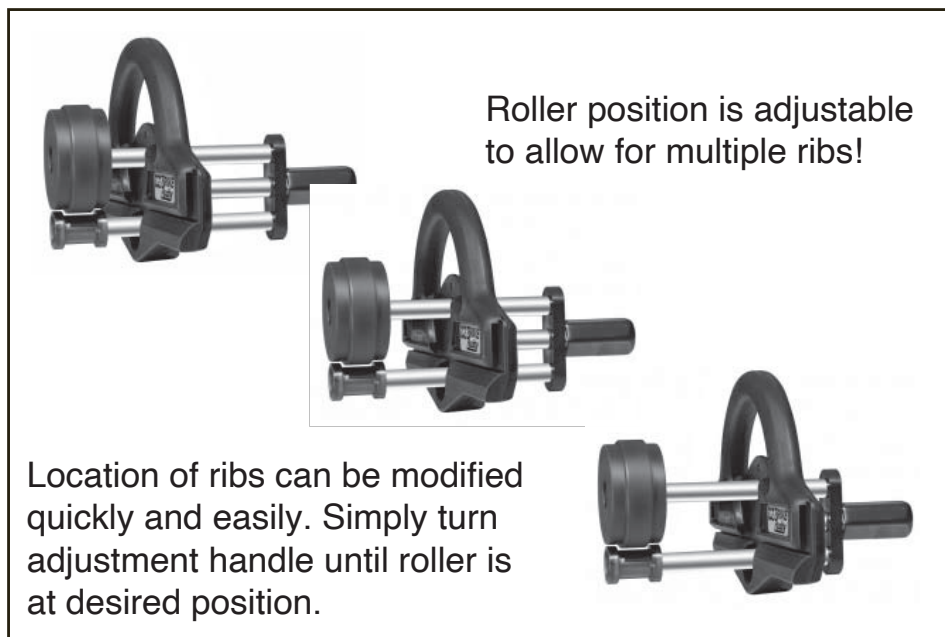

Patent No. 5,732,585

ASSEMBLY INSTRUCTIONS

1. Attach rollers.

To attach Fascia Rollers: Large roller goes on top axle and small roller on bottom axle. Rollers must be put on simultaneously with indented or counter bored side to outside. This allows the washer and cap screw to be installed.

To attach Brick Mold Rollers: Large roller should be placed on top axle first, then place smaller roller on bottom, counter bored side of rollers facing out.

2. Be sure to put flat side of roller against body and indented side of roller to the outside for the washer and cap screw.

3. Secure with Hex wrench.



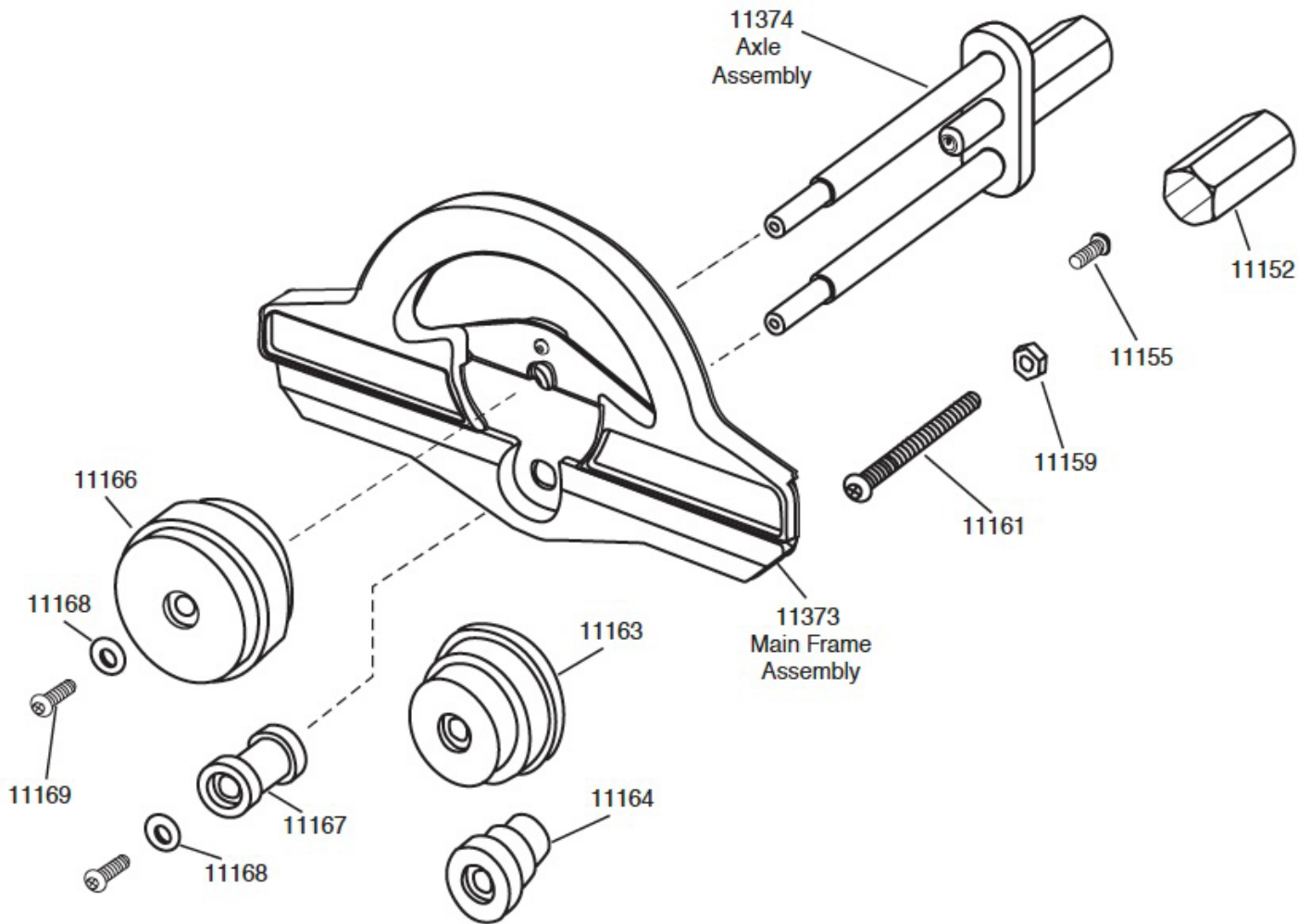

NOTE: All multiples of the same part may not be called out.

Part Number	Part Name
11152	Handle Grip
11155	Axle Cap Screw
11159	Jam Nut
11161	Carriage Bolt
11163	Large Brick Mold Roller
11164	Small Brick Mold Roller
11166	Large Fascia Roller
11167	Small Fascia Roller
11168	Washer
11169	Roller Screw Cap
11373	Main Frame Assembly
11374	Axle Assembly

USING THE BRAKE BUDDY TO PROCESS BRICK MOLD

1. Brick mold rollers will usually be adjusted in toward frame, almost touching frame.
2. Use Brake to make first bend. Bend should be 90 degrees and plain bottom lip or hemmed to a maximum of 1-1/2".
3. Pull material out and lock down brake handle. Be sure to pull out far enough so that Brake Buddy rollers do not touch your brake. Failure to do so will cause tool to veer away from desired line and ruin work piece or material.
4. Engage the front end of guide on Brake Buddy with a 90 degree bend. Advance Brake Buddy forward, pushing and maintaining slight pressure with your forward hand to maintain contact between the tool guide and work piece or material, while walking to other end of brake.
5. After using the Brake Buddy to strengthe and decorate, finish work piece as you normally would.



USING THE BRAKE BUDDY TO PROCESS FASCIA

1. Use Brake to make first bend in your Fascia. Bend should be 90 degrees and plain bottom lip or hemmed to a maximum of 1-1/2".
2. Pull material out and lock down brake handle. Be sure to pull out far enough so that Brake Buddy rollers do not touch your brake. Failure to do so will cause tool to veer away from desired line.
3. Engage the front end of guide on Brake Buddy with a 90 degree bend. Advance Brake Buddy forward, pushing and maintaining slight pressure with your forward hand to maintain contact between the tool guide and work piece or material, while walking to other end of brake.
4. After using the Brake Buddy to strengthen and decorate the Fascia, finish work piece as you normally would.



Tapco-Europe-Tools.com | +44 (0)1482 880478